

## MBZM P/R

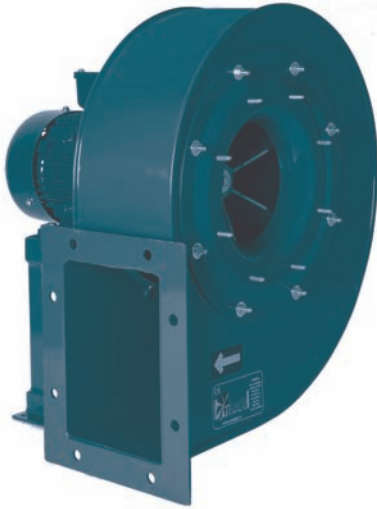

## АКСЕССУАРЫ ANCILLARIES ACCESSOIRES ZUBEHÖR



RFS



ASD



INT



PE



EA



EI



BA



SIL-C



RH

### РУ

#### ОБЩИЕ ХАРАКТЕРИСТИКИ:

Серийный ряд состоит из 14 разных типоразмеров от 220 до 1002, оснащенных 2 и 4-полюсными трехфазными электродвигателями. Производительность по воздуху от 1.116 м³/ч до 46.800 м³/ч. Максимальная рабочая температура - 130°C (безпрерывно). Статическое давление до 4410Па.

#### КОНСТРУКТИВНЫЕ ХАРАКТЕРИСТИКИ:

- корпус сделан из листа прокатной стали;
- полная сварка и укрепление корпуса;
- рабочее колесо изготовлено из листовой стали, оснащено прямыми лопастями и защищено от коррозии с помощью эмалированного покрытия, одностороннее всасывание;
- защита от коррозии с помощью напыления из эпоксидной смолы;
- стандартный асинхронный электродвигатель с короткозамкнутой обмоткой, так называемым «беличьим колесом», с классом защиты IP-55, классом изоляции F. Эталонное электрическое напряжение для однофазных электродвигателей составляет 230 В 50 Гц и для трехфазных, мощность которых не превышает 5,5 лошадиных сил (л.с.), - 230/400В 50 Гц и для более мощных электродвигателей - 400/690В 50Гц.

#### ПРИМЕНЕНИЕ:

- Предназначены для применения в вентиляционных каналах, а именно:
- отсос и перемещение загрязненного воздуха или воздуха наполненного твердыми частицами;
- отсос текстильного волокна.

#### ПОД ЗАКАЗ:

- вентиляторы, предназначенные для работы при напряжении 60Гц, индивидуальный вольтаж;
- 2-скоростной электродвигатель;
- вентиляторы жароустойчивые и взрывобезопасные, имеющие сертификат АТЕХ ("АТмосphere EXplosible");
- вентилятор предназначенный для работы при 250°C;
- оцинкованный корпус сделанный или корпус сделанный из нержавеющей стали.

### EN

#### GENERAL FEATURES:

Range with 14 sizes from the 220 until the 1002, provided with three phase 2 and 4 pole motors. Air-flow from 1.116 m³/h until 46.800 m³/h. Maximum air working temperature 130°C in continuous. Static pressures until 450 mmwg.

#### MANUFACTURING FEATURES:

- Rolled steel sheet housing.
- Fully welded and reinforced housing.
- Single inlet straight blade impeller manufactured of steel sheet and with reinforced with a welded ring and with enamelling finishing.
- Epoxy powder coat finishing.
- Squirrel cage asynchronous standard motor, IP-55 protection and rated class F insulation. Standard voltages 230V 50Hz for single phase motors, 230/400V 50Hz for three phase, motors up to 5,5HP and 400/690V 50Hz for higher powers.

#### APPLICATIONS:

- Specially designed for duct assembly, are suitable for:
- Transport of dirty air or air with mixed with solid materials.
- Textile fibre transport.

#### UNDER REQUEST:

- 60Hz fans and special voltages.
- 2 speed motors.
- Flameproof or explosionproof fans with ATEX certificated motors.
- Fan for air working temperatures up to 250°C.
- Hot dip galvanised or stainless steel fans.

### FR

#### CARACTÉRISTIQUES GÉNÉRALES:

Série composite par 14 tailles de la 220 à la 1002. Moteurs à 2 et 4 pôles triphasés. Débits de 1.100 m³/h à 46.800 m³/h. Température maximale de l'air 130°C en continu. Pressions statiques jusqu'à 450mmce.

#### CARACTÉRISTIQUES DE FABRICATION:

- Carcasse en tôle d'acier laminé.
- Turbine radiale tôle d'acier protégé contre la corrosion avec revêtement esmalte.
- Protégés contre la corrosion avec peinture époxy.
- Moteur asynchrone normalisé à cage d'écureuil degré de protection IP-55 et isolation électrique classe F. Tensions Standard 230V 50Hz pour moteurs monophasés. 230/400V 50Hz pour moteurs triphasés jusqu'à 5,5CV et 400/690V 50Hz pour puissances supérieures.

#### APPLICATIONS:

- Conçus pour montage en gaine.
- Transport de matériel solide.
- Aspiration de fibre textile.

#### OPTIONS DISPONIBLES:

- Ventilateurs pour travailler à 60Hz et tensions spéciales.
- Moteur 2 vitesses.
- Ventilateur anti-étincelles avec moteur anti-déflagrant ou anti-explosif certifié ATEX.
- Ventilateur préparé pour air à 250°C.
- Ventilateurs en tôle galvanisée ou acier inoxydable.

### DE

#### ALLGEMEINE MERKMALE:

Baureihe bestehend aus 14 verschiedenen Größen, von 220 bis 1002, ausgestattet mit 2- und 4-poligen Dreiphasenmotoren. Luftfördermenge 1.116 m³/h bis 46.800 m³/h. Maximale Arbeitstemperatur von 130 °C im Dauerbetrieb. Statische Drücke bis zu 450 mm Wassersäule.

#### BAULICHE MERKMALE:

- Gehäuse hergestellt aus Walzstahlblech.
- Komplett geschweißtes und verstärktes Gehäuse.
- Turbine mit geraden Lüfterflügeln und einfacher Ansaugung, Ausführung in Stahlblech und durch Emaille-Beschichtung vor Korrosion geschützt.
- Dank Pulverbeschichtung mit Epoxidharz vor Korrosion geschützt.
- Standardisierter Asynchron-Käfigläufermotor mit Schutzart IP-55 und Isolierklasse F. Standardspannungen von 230 V, 50 Hz, für Einphasenmotoren, 230/400 V, 50 Hz, für Dreiphasenmotoren bis 5,5 PS und 400/690 V, 50 Hz, für höhere Leistungsbereiche.

#### ANWENDUNGEN:

- Grundlegende Anwendungsbereiche dieser für den Rohreinbau gedachten Lüfter sind:
- Ansaugung über Partikelabscheider vom Typ Zyklon und jede Form von Transport von verschmutzter oder mit Feststoffen angereicherter Luft.
- Ansaugung von Textilfasern.

#### AUF ANFRAGE:

- Lüfter, die mit 60 Hz, besonderen Spannungen usw. arbeiten.
- Motor mit 2 Geschwindigkeitsstufen.
- Explosionsgeschützte oder flammensichere Lüfter mit Motor mit ATEX-Zertifikat.
- Ventilator ausgelegt für 250 °C.
- Ventilatoren hergestellt aus feuerverzinktem Blech oder rostfreiem Edelstahl.

**MBZM P/R**

**DIMENSIONES / DIMENSIONS / ENCOMBREMENT / РАЗМЕРЫ, ММ**

Модель	A	B	C	D	E	F	G	H	H1	H2	d	d1	d2	n°	Ø	a	b	α1	b1	α2	b2	n1xp	n2xp	n°
MBZM 220 T2 1/2 P/R	62	333	360	165	425	150	55	255	165	255	130	150	170	4	8	124	103	145	125	164	143	-	-	4
MBZM 251 T2 3/4 P/R	86	393	441	195	526	175	76	315	195	315	185	219	255	8	8	207	148	241	182	277	218	1x112	1x112	8
MBZM 252 T2 1 P/R	86	413	441	195	526	175	76	315	195	315	185	219	255	8	8	207	148	241	182	277	218	1x112	1x112	8
MBZM 281 T2 1,5 P/R	95	432	477	200	610	202	86	375	200	375	205	241	275	8	8	231	166	265	200	301	236	1x112	1x112	8
MBZM 282 T2 2 P/R	95	472	477	200	610	202	86	375	200	375	205	241	275	8	8	231	166	265	200	301	236	1x112	1x112	8
MBZM 311 T2 2 P/R	105	490	527	225	658	229	96	400	225	400	228	265	298	8	8	258	185	292	219	328	255	1x112	2x112	10
MBZM 312 T2 3 P/R	105	490	527	225	658	229	96	400	225	400	228	265	298	8	8	258	185	292	219	328	255	1x112	2x112	10
MBZM 351 T2 4 P/R	115	585	600	255	740	253	107	450	255	450	255	292	325	8	10	288	205	332	249	368	285	1x125	2x125	10
MBZM 352 T2 5,5 P/R	115	585	600	255	740	253	107	450	255	450	255	292	325	8	10	288	205	332	249	368	285	1x125	2x125	10
MBZM 401 T2 7,5 P/R	127	671	655	285	815	286	118	500	285	500	285	332	365	8	10	332	229	366	273	402	309	1x125	2x125	10
MBZM 402 T2 10 P/R	127	671	655	285	815	286	118	500	285	500	285	332	365	8	10	332	229	366	273	402	309	1x125	2x125	10
MBZM 452 T2 15 P/R	141	834	735	320	915	321	131	560	320	560	320	366	400	8	10	361	256	405	300	441	336	1x125	2x125	10
MBZM 501 T2 20 P/R	157	866	832	360	1000	355	148	600	360	600	360	405	440	8	10	404	288	448	332	484	368	2x125	3x125	14
MBZM 502 T2 30 P/R	157	866	832	360	1000	355	148	600	360	600	360	405	440	8	10	404	288	448	332	484	368	2x125	3x125	14
MBZM 454 T4 2 P/R	141	566	735	320	915	321	131	560	320	560	320	366	400	8	10	361	256	405	300	441	336	1x125	2x125	10
MBZM 503 T4 3 P/R	157	668	832	360	1000	355	148	600	360	600	360	405	440	8	10	404	288	448	332	484	368	2x125	3x125	14
MBZM 504 T4 4 P/R	157	668	832	360	1000	355	148	600	360	600	360	405	440	8	10	404	288	448	332	484	368	2x125	3x125	14
MBZM 561 T4 5,5 P/R	177	712	940	400	1126	390	165	670	400	670	405	448	485	12	10	453	322	497	366	533	402	2x125	3x125	14
MBZM 562 T4 7,5 P/R	177	777	940	400	1126	390	165	670	400	670	405	448	485	12	10	453	322	497	366	533	402	2x125	3x125	14
MBZM 631 T4 10 P/R	195	816	1052	450	1260	439	185	750	450	750	455	497	535	12	10	507	361	551	405	587	441	2x125	3x125	14
MBZM 632 T4 15 P/R	195	952	1052	450	1260	439	185	750	450	750	455	497	535	12	10	507	361	551	405	587	441	2x125	3x125	14
MBZM 711 T4 15 P/R	216	1002	1189	500	1416	500	202	670	500	850	505	551	585	12	10	569	404	629	464	669	504	2x160	3x160	14
MBZM 712 T4 20 P/R	216	1002	1189	500	1416	500	202	670	500	850	505	551	585	12	10	569	404	629	464	669	504	2x160	3x160	14
MBZM 801 T4 25 P/R	241	1071	1340	560	1591	560	226	755	560	950	565	629	665	12	10	638	453	698	513	738	553	2x160	3x160	14
MBZM 802 T4 40 P/R	241	1146	1340	560	1591	560	226	755	560	950	565	629	665	12	10	638	453	698	513	738	553	2x160	3x160	14
MBZM 901 T4 50 P/R	275	1277	1500	630	1780	630	253	850	630	1060	635	698	735	12	12	715	507	775	567	815	607	2x160	4x160	16
MBZM 902 T4 60 P/R	275	1277	1500	630	1780	630	253	850	630	1060	635	698	735	12	12	715	507	775	567	815	607	2x160	4x160	16
MBZM 1001 T4 75 P/R	308	1359	1685	710	1993	710	284	950	710	1180	715	775	815	16	12	801	569	871	639	921	689	2x200	3x200	14
MBZM 1002 T4 100 P/R	308	1489	1685	710	1993	710	284	950	710	1180	715	775	815	16	12	801	569	871	639	921	689	2x200	3x200	14

**MBZM 220-500**

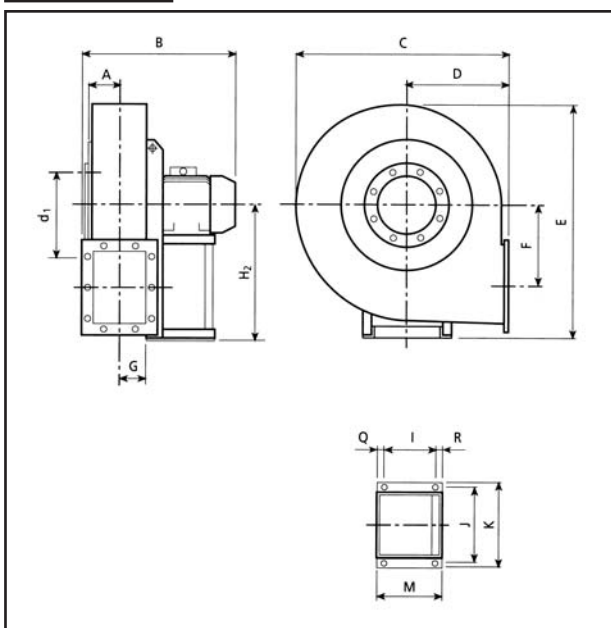

**MBZM 560-630**

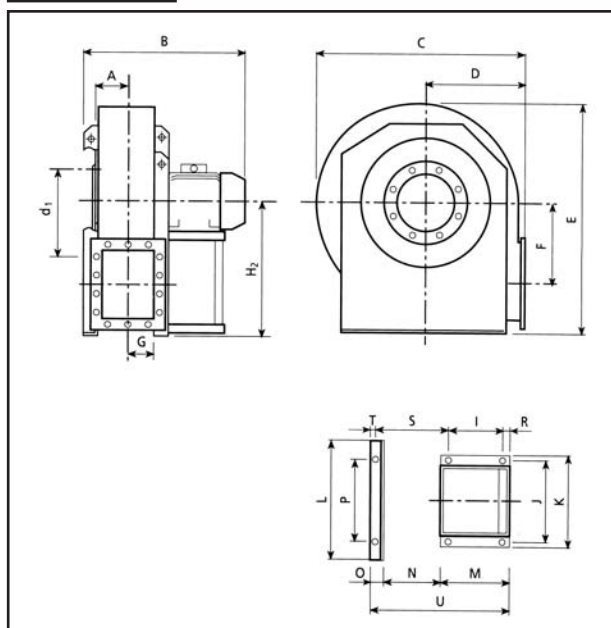

**MBZM P/R**

Модель	Ø	I	J	K	L	M	N	O	P	Q	R	S	T	U	Ø
MBZM 220 T2 1/2 P/R	8	121	203	225	-	180	-	-	-	45	14	-	-	-	10
MBZM 251 T2 3/4 P/R	12	121	203	225	-	180	-	-	-	45	14	-	-	-	10
MBZM 252 T2 1 P/R	12	121	203	225	-	180	-	-	-	45	14	-	-	-	10
MBZM 281 T2 1,5 P/R	12	121	203	225	-	180	-	-	-	45	14	-	-	-	10
MBZM 282 T2 2 P/R	12	133	234	260	-	205	-	-	-	55	17	-	-	-	10
MBZM 311 T2 2 P/R	12	133	234	260	-	205	-	-	-	55	17	-	-	-	10
MBZM 312 T2 3 P/R	12	133	234	260	-	205	-	-	-	55	17	-	-	-	10
MBZM 351 T2 4 P/R	12	197	289	324	-	250	-	-	-	30	23	-	-	-	10
MBZM 352 T2 5,5 P/R	12	197	289	324	-	250	-	-	-	30	23	-	-	-	10
MBZM 401 T2 7,5 P/R	12	237	337	372	-	300	-	-	-	40	23	-	-	-	12
MBZM 402 T2 10 P/R	12	237	337	372	-	300	-	-	-	40	23	-	-	-	12
MBZM 452 T2 15 P/R	12	337	395	440	-	415	-	-	-	50	28	-	-	-	14
MBZM 501 T2 20 P/R	12	357	395	440	-	415	-	-	-	50	28	-	-	-	14
MBZM 502 T2 30 P/R	12	357	434	488	-	460	-	-	-	70	33	-	-	-	17
MBZM 454 T4 2 P/R	12	133	234	260	-	205	-	-	-	55	17	-	-	-	10
MBZM 503 T4 3 P/R	12	197	289	324	-	250	-	-	-	30	23	-	-	-	10
MBZM 504 T4 4 P/R	12	197	289	324	-	250	-	-	-	30	23	-	-	-	10
MBZM 561 T4 5,5 P/R	12	197	289	324	692	250	327	53	632	-	23	387	23	630	12
MBZM 562 T4 7,5 P/R	12	237	337	372	692	300	327	53	632	-	23	397	23	680	12
MBZM 631 T4 10 P/R	12	237	337	372	762	300	366	53	702	-	23	436	23	719	12
MBZM 632 T4 15 P/R	12	337	395	440	762	415	366	53	702	-	28	400	23	834	14
MBZM 711 T4 15 P/R	14	316	772	826	915	415	404	60	772	-	39	497	27	879	20
MBZM 712 T4 20 P/R	14	316	772	826	915	415	404	60	772	-	39	497	27	879	20
MBZM 801 T4 25 P/R	14	361	862	926	1045	460	453	80	862	-	39	546	47	993	20
MBZM 802 T4 40 P/R	14	401	862	926	1045	500	453	80	862	-	39	546	47	1033	20
MBZM 901 T4 50 P/R	14	441	962	1026	1145	540	507	80	962	-	39	600	47	1127	20
MBZM 902 T4 60 P/R	14	441	962	1026	1145	540	507	80	962	-	39	600	47	1127	20
MBZM 1001 T4 75 P/R	14	500	1056	1128	1255	600	569	100	1056	-	45	657	67	1269	20
MBZM 1002 T4 100 P/R	14	565	1056	1128	1255	690	569	100	1056	-	45	657	67	1359	20

**MBZM 710-1000**

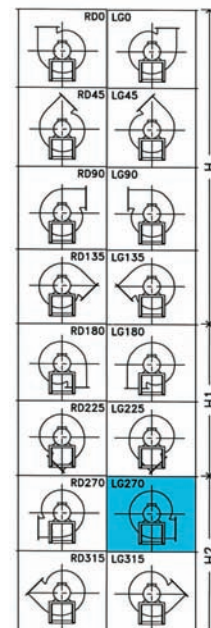
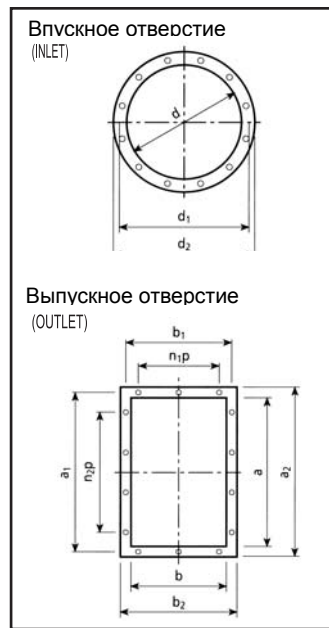
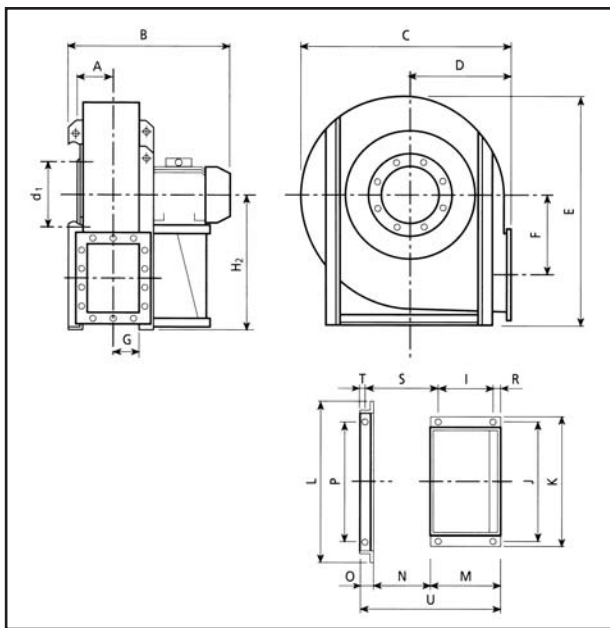

## MBZM P/R

### SERIE TRIFÁSICA / THREE PHASE / SÉRIE TRIPHASÉE / ТРИФАЗНЫЕ МОДЕЛИ

Модель	Мах об./мин	I max. (A)			кВт	m³/h	дБ(A)	кг
		230	400	690				
MBZM 220 T2 1/2 P/R	2.780	1,97	1,14	-	0,37	1.116	69	11
MBZM 251 T2 3/4 P/R	2.800	2,43	1,4	-	0,55	1.116	71	26
MBZM 252 T2 1 P/R	2.810	3,27	1,89	-	0,75	1.548	72	29
MBZM 281 T2 1,5 P/R	2.820	5,01	2,9	-	1,1	1.548	73	33
MBZM 282 T2 2 P/R	2.860	6,61	3,02	-	1,5	2.196	74	37
MBZM 311 T2 2 P/R	2.860	6,61	3,02	-	1,5	2.196	76	43
MBZM 312 T2 3 P/R	2.860	8,2	4,7	-	2,2	3.096	77	46
MBZM 351 T2 4 P/R	2.800	12,48	7,21	-	3	3.096	79	74
MBZM 352 T2 5,5 P/R	2.840	14,9	8,61	-	4	4.320	80	80
MBZM 401 T2 7,5 P/R	2.850	-	11	6,3	5,5	4.320	83	109
MBZM 402 T2 10 P/R	2.850	-	14,6	8,4	7,5	6.120	84	115
MBZM 452 T2 15 P/R	2.915	-	21,5	12,4	11	8.280	87	198
MBZM 501 T2 20 P/R	2.920	-	29	16,7	15	8.280	90	222
MBZM 502 T2 30 P/R	2.940	-	40	23	22	11.880	91	274
MBZM 454 T4 2 P/R	1.420	6,32	3,65	-	1,5	4.320	71	106
MBZM 503 T4 3 P/R	1.420	9,2	5,31	-	2,2	4.320	72	126
MBZM 504 T4 4 P/R	1.410	11,53	6,66	-	3	6.120	74	134
MBZM 561 T4 5,5 P/R	1.440	17,1	9,86	-	4	6.120	75	148
MBZM 562 T4 7,5 P/R	1.450	-	13,14	7,3	5,5	8.280	76	175
MBZM 631 T4 10 P/R	1.420	-	16,5	9,5	7,5	8.280	78	200
MBZM 632 T4 15 P/R	1.430	-	21	12,1	11	11.880	80	274
MBZM 711 T4 15 P/R	1.430	-	21	12,1	11	11.880	83	338
MBZM 712 T4 20 P/R	1.460	-	28,4	16,41	15	16.920	84	368
MBZM 801 T4 25 P/R	1.450	-	37	21,38	18,5	16.920	85	443
MBZM 802 T4 40 P/R	1.465	-	54,8	31,6	30	23.760	87	509
MBZM 901 T4 50 P/R	1.475	-	65,2	37,6	37	23.760	90	598
MBZM 902 T4 60 P/R	1.475	-	77,3	44,6	45	33.840	92	638
MBZM 1001 T4 75 P/R	1.475	-	94,3	54,5	55	33.840	96	800
MBZM 1002 T4 100 P/R	1.485	-	129	74,5	75	46.800	97	918

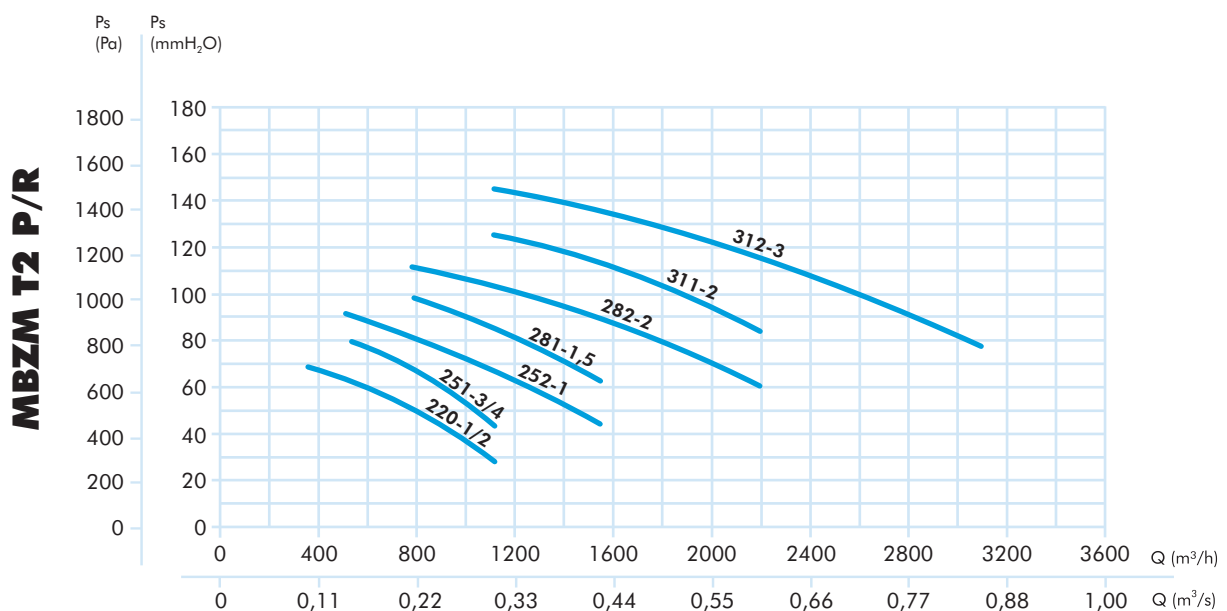

**MBZM P/R**

